

## Omega ICD Intelligent Colour Display

Cosworth's Omega ICD is a widescreen TFT colour display coupled with a fully featured data logger in a single attractive aluminium housing.

Using a widescreen 6.2" TFT, coupled with dedicated graphic processors, multiple fast and feature rich pages of information can be displayed to a variety of different users. Super bright tri-colour shift and alarm LED's complement the display to provide a compelling display of data.

Configured using Pi Toolset PC software all the leading data logging features are included – powerful on-board Pi maths, GPS or Pi infra-red beacons, GPS or digital speeds, qualifying mode, alarms, overlays, info messages, zeroing etc - are all possible and configurable by the user.

Data is analysed with Pi Toolbox PC software – an industry standard analysis tool packed with features.



Designed to be a central part of a vehicle system, with an Ethernet hub built in, 12V or 24V systems, programmable excitations, 4 CAN ports, LIN and serial ports, 20 analogue channels, 16 digitals there is plenty of input and output capability.

### Specifications

Electrical Data	
Operating voltage	6.5 to 35V
Current Consumption	570mA @ 12V
Display	6.2" (16:9) TFT 800 x 480 Contrast Ratio 600:1 Luminance 400cd/m <sup>2</sup> hard antiglare coating Viewing angle ±75° Hor / ±70°Vert
Logging	1GB memory / 1kHz max logging rate 50KB/s total logging bandwidth
Digital Inputs	4 x high freq (10kHz) inputs suitable for hall effect/VRS/DF11i sensors 1 x high freq (10kHz) suitable for hall effect / VRS sensors 1 x Lap beacon 10 x switch inputs
Analogue Inputs	20 x Analogue inputs (4 with configurable 330Ω resistors) (2 with configurable 10kΩ resistors)
CAN Ports	4 x Independent CAN ports Max BAUD rate: 1MBit/s 64 message buffers per port Software selectable 120Ω resistor
Serial Ports	3 x bi-directional RS232 ports Max BAUD rate: 115200

Electrical Data	
Ethernet	1 x 100MB/s PC Setup 1 x 100MB/s Expansion
Shift/Alarm LEDs	16 x RGB LEDs
LIN Bus	1 x LIN Bus Master – for custom applications
Internal Sensors	Battery Voltage Monitoring Internal Temperature Tri-axis accelerometer ±5G

Mechanical Data	
Size excluding connectors	190 x 116 x 40 mm
Weight	640 grams
Environmental	IP65
Operating Temperature	-20°C to +55°C
Storage Temperature	-30°C to +80°C

### Ordering Information

Part Number	
Omega ICD	01D-032953

## Dimensions

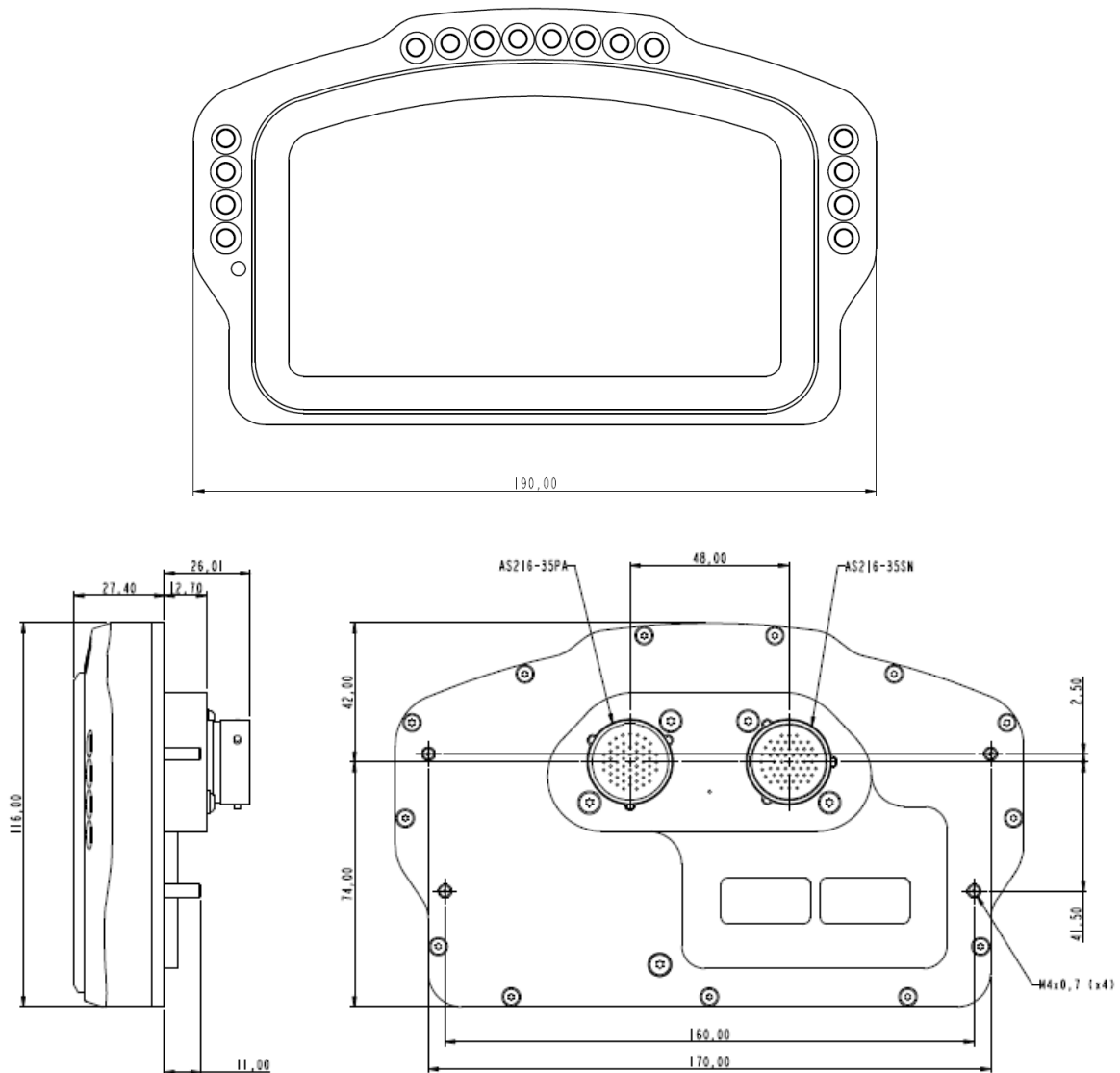

All Dimensions in mm

## Installation

When installing the Omega ICD:

- Ensure unit is protected against severe vibrations by mounting using supplied AV mounting kit. Also ensure unit is not fouling other structures which may experience severe vibrations.
- Ensure unit is positioned in an area with an ambient temperature of less than 50°C or with sufficient cooling air flow to prevent over heating.
- Ensure unit is mounted away from sources of electrical interference
- Ensure unit is mounted in position where unit will not come into contact with water
- Do not ground the case, use the power pins provided

## Connector Information

### C1 - System Connector (Yellow)

Connector	Mating Connector
AS216-35PA	AS616-35SA

Pin	Function	Signal Description
1	BAT-	Battery supply -ve
2	BAT+	Battery supply +ve (shared with pins 2 and 3)
3	BAT+	Battery supply +ve (shared with pins 2 and 3)
4	5/12Vout1	5V or 12V software selectable excitation #1
5	Gnd	Ground <sup>1</sup>
6	LIN	LIN Bus Master
7	DI7	Digital Input 7 - Switch Input (10k pull up)
8	ETHTX+1	Ethernet TX+ for PC comms
9	ETHTX-1	Ethernet TX- for PC comms
10	5/12Vout2	5V or 12V software selectable excitation #2
11	CANH1	CANH for port 1 <sup>2</sup>
12	CANL1	CANL for port 1 <sup>2</sup>
13	Gnd	Ground <sup>1</sup>
14	5Vout1	5V excitation #1 (shared with pins 14 and 15)
15	5Vout1	5V excitation #1 (shared with pins 14 and 15)
16	Serial 4 (Tx)	Serial Port 4 Tx (RS232 data from ICD) <sup>6</sup>
17	Serial 3 (Rx)	Serial Port 3 Rx (RS232 data to ICD)
18	CANH2	CANH for port 2 <sup>2</sup>
19	CANL2	CANL for port 2 <sup>2</sup>
20	AI1-PD330R	Analogue Input 1 with software selectable 330Ω pull-down
21	DI8	Digital Input 8 – Switch Input (10k pull up)
22	DI9	Digital Input 9 – Switch Input (10k pull up)
23	ETHRX+1	Ethernet RX+ for PC comms
24	ETHRX-1	Ethernet RX- for PC comms
25	Gnd	Ground <sup>1</sup>
26	Gnd	Ground <sup>1</sup>
27	AI2-PD330R	Analogue Input 2 (with software selectable 330Ω pull-down)
28	Gnd	Ground <sup>1</sup>
29	AI3-PD330R	Analogue Input 3 (with software selectable 330Ω pull-down)
30	AI4-PD330R	Analogue Input 4 (with software selectable 330Ω pull-down)
31	Gnd	Ground <sup>1</sup>
32	BCN	Digital Input 5 – Lap Beacon Input
33	DI1	Digital Input 1 – Wheelspeed hall effect/VRS/DF11i

<sup>1</sup> All grounds are shared

<sup>2</sup> CAN termination resistors are software selectable

Pin	Function	Signal Description
34	DI2	Digital Input 2 - Wheelspeed hall effect/VRS/DF11i
35	AI5-PD10K	Analogue Input 5 (with software selectable 10kΩ pull-down)
36	AI6-PD10K	Analogue Input 6 (with software selectable 10kΩ pull-down)
37	AI7	Analogue Input 7
38	ETHTX+2	Ethernet TX+ 2 ( connects to internal Ethernet hub) <sup>3</sup>
39	ETHTX-2	Ethernet TX- 2 (connects to internal Ethernet hub) <sup>3</sup>
40	DI3	Digital Input 3 - Wheelspeed hall effect/VRS/DF11i
41	DI4	Digital Input 4 - Wheelspeed hall effect/VRS/DF11i
42	AI8	Analogue Input 8
43	Gnd	Ground <sup>1</sup>
44	5Vout2	5V excitation #2 (shared with pins 44, 45)
45	5Vout2	5V excitation #2 (shared with pins 44, 45)
46	+12Vout	12V excitation <sup>4</sup>
47	RPM	Digital Input 6 - RPM Input
48	USB-GND	Debug port USB ground
49	USB-VBUS	Debug port USB VBUS
50	DI10	Digital Input 10 – Switch Input (10k pull up)
51	ETHRX+2	Ethernet RX+ 2 (connects to internal Ethernet hub) <sup>3</sup>
52	ETHRX-2	Ethernet RX- 2 (connects to internal Ethernet hub) <sup>3</sup>
53	USB-D+	Debug port USB data +ve
54	USB-D-	Debug port USB data -ve
55	DI11	Digital Input 11 – Switch Input (10k pull up)

**C2 - Sensors Connector (Red)**

Connector	Mating Connector
AS216-35SN	AS616-35PN

Pin	Function	Signal Description
1	5/12Vout4	5V or 12V software selectable excitation #4
2	AI17	Analogue Input 17
3	AI20	Analogue Input 20
4	+12Vout	12V excitation <sup>4</sup>
5	Gnd	Ground1
6	DI12	Digital Input 12 – Switch Input (10k pull up)
7	DI13	Digital Input 13 – Switch Input (10k pull up)
8	Gnd	Ground1
9	HSD1	High Side Driver 1 <sup>5</sup>
10	+12Vout	12V excitation <sup>4</sup>

<sup>3</sup> Inside the ICD there is an Ethernet Hub, two ports are broken out to the main connector, this allows users to connect other Ethernet devices to the ICD, for example an IPS32 or ECU etc

Pin	Function	Signal Description
11	+12Vout	12V excitation <sup>4</sup>
12	0V	Ground <sup>1</sup>
13	AI9	Analogue Input 9
14	AI10	Analogue Input 10
15	AI11	Analogue Input 11
16	N/C	Do not connect to this pin, it is reserved for future development.
17	CANH3	CANH for port 3 <sup>2</sup>
18	CANL3	CANL for port 3 <sup>2</sup>
19	+12Vout	12V excitation <sup>4</sup>
20	+12Vout	12V excitation <sup>4</sup>
21	AI12	Analogue Input 12
22	Gnd	Ground <sup>1</sup>
23	N/C	Do not connect to this pin, it is reserved for future development.
24	Gnd	Ground <sup>1</sup>
25	Gnd	Ground <sup>1</sup>
26	Gnd	Ground <sup>1</sup>
27	+12Vout	12V excitation <sup>4</sup>
28	AI15	Analogue Input 15
29	Gnd	Ground <sup>1</sup>
30	AI16	Analogue Input 16
31	HSD2	High Side Driver 2 <sup>5</sup>
32	Serial 3 (Tx)	Serial Port 3 Tx (RS232 data from ICD)
33	AI13	Analogue Input 13
34	AI14	Analogue Input 14
35	Gnd	Ground <sup>1</sup>
36	AI18	Analogue Input 18
37	AI19	Analogue Input 19
38	Gnd	Ground <sup>1</sup>
39	5/12Vout3	5V or 12V software selectable excitation #3
40	Serial 4 (Tx)	Serial Port 4 Tx (RS232 data from ICD) <sup>6</sup>
41	Serial 2 (Tx)	Serial Port 2 Tx (RS232 data from ICD)
42	N/C	Do not connect to this pin, it is reserved for future development.
43	Gnd	Ground <sup>1</sup>
44	DI14	Digital Input 14 – Switch Input (10k pull up)
45	Serial 1 (Rx)	Serial Port 1 Rx (RS232 data to ICD)
46	N/C	Do not connect to this pin, it is reserved for future development.

<sup>4</sup> 12V excitation also shared with Sensor connector pins 4, 10, 11, 19, 20, 27 and System connector pin 46

<sup>5</sup> With High Side Drive return current to be taken outside of ICD

<sup>6</sup> Serial Port 4 Tx (RS232 data from ICD) shared with Sensor connector pin 40 and System connector pin 16

Pin	Function	Signal Description
47	Serial 4 (Rx)	Serial Port 4 Rx (RS232 data to ICD)
48	CANH4	CANH for port 4 <sup>2</sup>
49	DI16	Digital Input 16 – Switch Input (10k pull up)
50	CUSB-VBUS	Colibri module USB VBUS (future development)
51	CUSB-GND	Colibri module USB ground (future development)
52	DI15	Digital Input 15 – Switch Input (10k pull up)
53	CANL4	CANL for port 4 <sup>2</sup>
54	CUSB-D+	Colibri module USB data +ve (future development)
55	CUSB-D-	Colibri module USB data –ve (future development)

## **Recycling and Environmental Protection**

Cosworth Electronics is committed to conducting its business in an environmentally responsible manner and to strive for high environmental standards.

### ***Manufacture***

Cosworth products comply with the appropriate requirements of the Restriction of Hazardous Substances (RoHS) directive (where applicable).

### ***Disposal***

Electronic equipment should be disposed of in accordance with regulations in force and in particular in accordance with the Waste in Electrical and Electronic Equipment directive (WEEE).

### ***Battery***

This equipment contains a rechargeable battery (Lithium Vanadium Pentoxide).

The equipment may be returned to Cosworth Electronics for a replacement battery. (A charge will be made for this service).

Removal of the battery by the user may void any warranty on the equipment.

To remove the battery for recycling:

Remove the case cover(s).

Remove the printed circuit boards from the case.

Remove the battery from the printed circuit board.

Dispose of the battery in accordance with regulations in force.

